

MODEL WSP-HS400

(4inch Mobile Printer)

Rev. 2.0

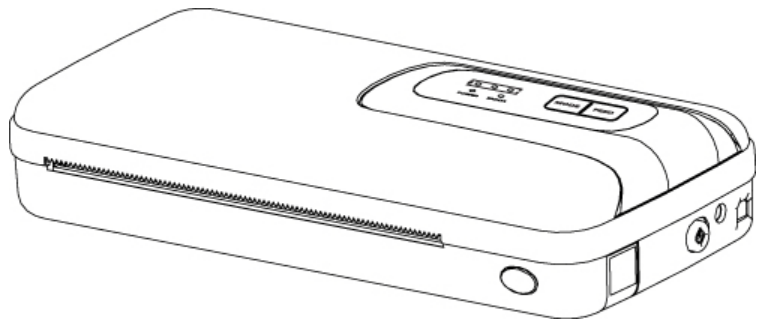

WOOSIM SYSTEMS Inc.

**#501, Daerung Technotown 3th,
448, Gasan-Dong, GeumChun-Ku,
Seoul, Korea**

Tel : +82-2-2107-3700

Fax : +82-2-2107-3707

URL: <http://www.woosim.com>

All specifications are subjected to change without notice

! Copyright

WSP-HS400 mobile printer operator's manual.

Copyright 2008 by Woosim Systems Inc.

All rights reserved.

The information contained in this manual is the property of Woosim System Inc. and may not be reproduced in whole or in part without the prior written permission of Woosim Systems Inc.

! Trademark



a registered trademark of Woosim Systems Inc.

All other trademark are the properties of their respective companies.

! Caution

Some semiconductor devices are easily damaged by static electricity. You should turn the printer "OFF", before you connect or removed the cable on the rear side, in order to guard the printer against the static electricity.

If the printer is damaged by the static electricity, you should turn the printer "OFF".

! Notice

The contents of this manual are subject to change without notice.

! Introduction

The **WSP-HS400** is suitable designed for use with a growing variety of mobile devices. IrDA/Serial or Bluetooth/Serial interfaces make the WSP-HS400 the perfect comrade for applications such as point of transaction warehousing, distribution, point of sales, hospitality, gaming and healthcare.

The general features of **WSP-HS400** printer are as follows:

- U Pocket size (174.6mm x 82mm x 36.1mm).
- U Light weight(379.5g) for true mobility.
- U Very silent printing thru direct thermal printing method.
- U High speed (50mm/sec, MAX)
- U High resolution (203dpi, 8dot/mm)
- U UART(RS-232C or TTL) , Bluetooth Ver2.1+EDR
IrDA Ver1.0(SIR)[option] Interface
- U Intuitive LED's indicate Power(on/off),Error and Battery status
- U Support text and graphic printing
- U The use of single sheet printing
- U Easier paper roll loading by CLAMSHELL design.
- U Printer door open & Paper-out sensor
- U Easier maintenance with self-diagnostic.
- U In field programming – Update Firmware, Download Fonts and Logos
- U Microsoft Windows 98 / ME / 2000 / XP / VISTA / 7 compatible.
- U Flow control : Software (XON/XOFF)
Hardware flow control not supported in printer.
- U Agency Approvals



! Operating Precautions

Please follow the precautions below to enjoy and maintain the full performance of the printer.

U Using the Printer

- Be careful not to drop or bump the printer on a hard surface.
- Do not install the printer in direct sunlight or such areas.
Suitable environment for the use of the printer is as follows:
Operating temperature :-10°C to 50°C
Relative humidity : 10% to 90% (No condensation)
- Do not install the printer near devices that generate strong electromagnetic fields such as a copy machine.
- Do not open the platen cover during printing .
- Do not remove or reinstall the communication cable during printing or transmission.
- Do not touch the connectors of the communication during printing.
- Switch the POWER OFF when not in use.
- Do not use alcohol or other solvent.
- The AC adapter, the battery charger and the battery pack may become warm when in use. This is normal and is not a malfunction.
- When the battery pack is used at low temperature, the length of time the printer can be used may be shortened.

U Thermal Paper Handling

- Store the thermal paper in a cool, dry and dark place.
- Do not rub the paper with hard object.
- Do not leave the paper with hard object.
- Do not allow plastic film, erasers, or adhesive tape to touch the paper for long periods.
- Do not stack the thermal paper with diazo copies immediately after copying or wet-type copies.
- Do not use chemical glue.
- Always use the clean thermal paper.

CONTENTS

| | |
|---|----|
| 1. Outline | 6 |
| 1.1. Model classifications | 6 |
| 1.2. Product Part Number System..... | 6 |
| 1.3. Specifications..... | 7 |
| 2. Setting up the printer | 9 |
| 2.1. Printer & Accessories | 9 |
| 2.2. Printer Features | 10 |
| 2.2.1. Part name | 10 |
| 2.2.2. Dimensions | 10 |
| 2.3. Replacing paper roll..... | 11 |
| 2.4. Power supply | 13 |
| 2.4.1. Internal power supply | 13 |
| 2.4.2. Installing the Battery..... | 13 |
| 2.4.3. Recharging the battery pack..... | 14 |
| 2.5. Set operation mode | 15 |
| 3. Interface | 19 |
| 3.1. UART(RS-232C or TTL) | 19 |
| 3.2. Infrared data communication | 20 |
| 3.3. Bluetooth | 21 |
| 4. Using the printer | 22 |
| 4.1. Control panel | 22 |
| 4.2. Self test | 23 |
| 5. Consumable parts | 24 |
| 5.1. Recommended paper..... | 24 |
| 5.2. Printing position..... | 24 |

1. Outline

1.1. Model classifications

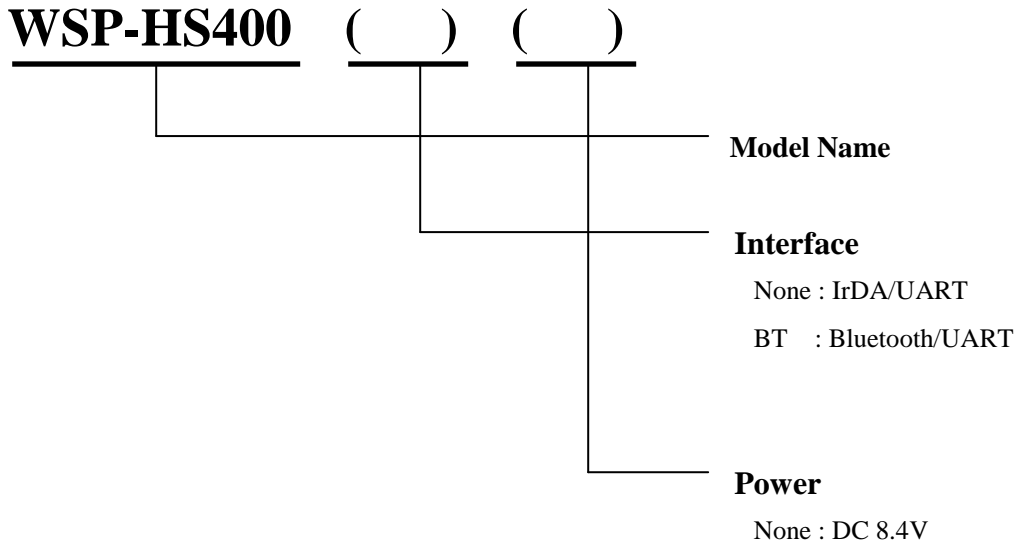

1.2. Product Part Number System

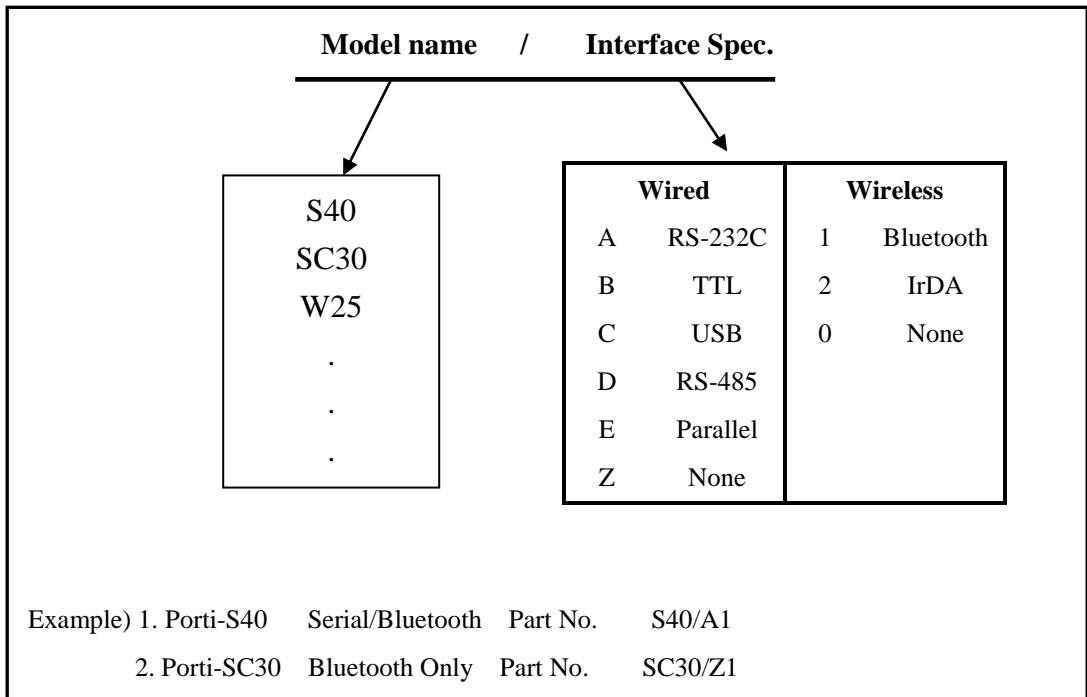

1.3. Specifications

| Item | Specification |
|---------------------|---|
| Printing method | Direct thermal line printing |
| Characters per line | 92cpl (MAX) |
| Character size | Eng. : 9*24dots, 12*24dots Kor. : 16*24dots, [24*24dots] |
| Optional Characters | Simplified/Traditional Chinese, Arabic, Cyrillic, Russian, Turkish, Greek, Japanese, Persian, Latin9 and Others upon request. |
| Resolution | 203dpi, 8dots/mm |
| Print width | 113mm |
| Printing speed | 50mm / sec (MAX) |
| Dimensions | 174.6 * 82 * 36.1 mm |
| Weight | 379g (Including battery) |
| Interface | UART(RS-232C or TTL), Bluetooth Ver2.1+EDR, IrDA Ver1.0 (SIR)[option] |
| Paper supplied | Thermal Label paper (116mm wide) (Standard Model) |
| Barcode supplied | 1-dimension : Code128, Code39, I2/5, Code93 UPC, EAN, KAN, JAN, CODABAR 2-dimension : PDF417, QR Code, DATA Matrix |
| Black mark | Support black mark detection |
| H/W Spec. | MCU : 32bits RISC, FLASH : 4Mbytes, RAM : 8Mbytes |
| Receive buffer size | 1M bytes |
| Battery | Rechargeable 7.4V DC, 1700mAh (Li-ion) |
| Battery duration | 1 hour continuous printing |
| Battery Charger | Input (100~250VAC, 50~60Hz) Output(8.4VDC/0.8A), 4hours full charge time |

(continue...)

| Item | Specification | |
|--------------------------------------|---------------|--|
| Environment Conditions | Temperature | -10°C ~ 50°C (operating) -10°C ~ 70°C (storage) |
| | Humidity | 30% - 80% (operating) 10% - 90% (storage) |
| MCBF (Mean Cycle Between failure) | Mechanical | 37,000,000 lines |
| | Head | Approximately 50 Km |

< Table 1 >

2. Setting up the printer

2.1. Printer & Accessories

Your printer box should include these items. If any items are damaged or missing, please contact your dealer for assistance.

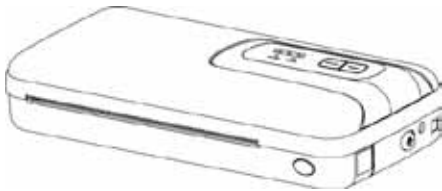

WSP-HS400

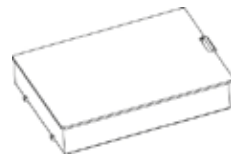

Battery Pack



Battery Charger adaptor

OPTIONAL



Communication Cable

2.2. Printer Features

2.2.1. Part name

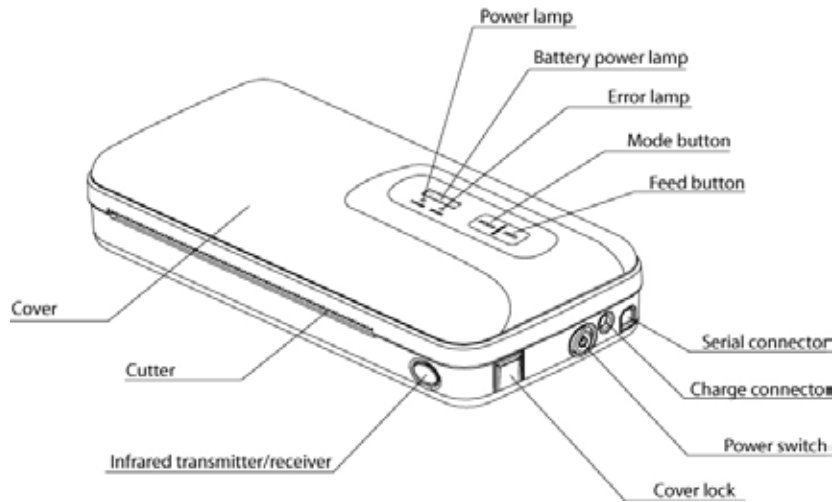

2.2.2. Dimensions

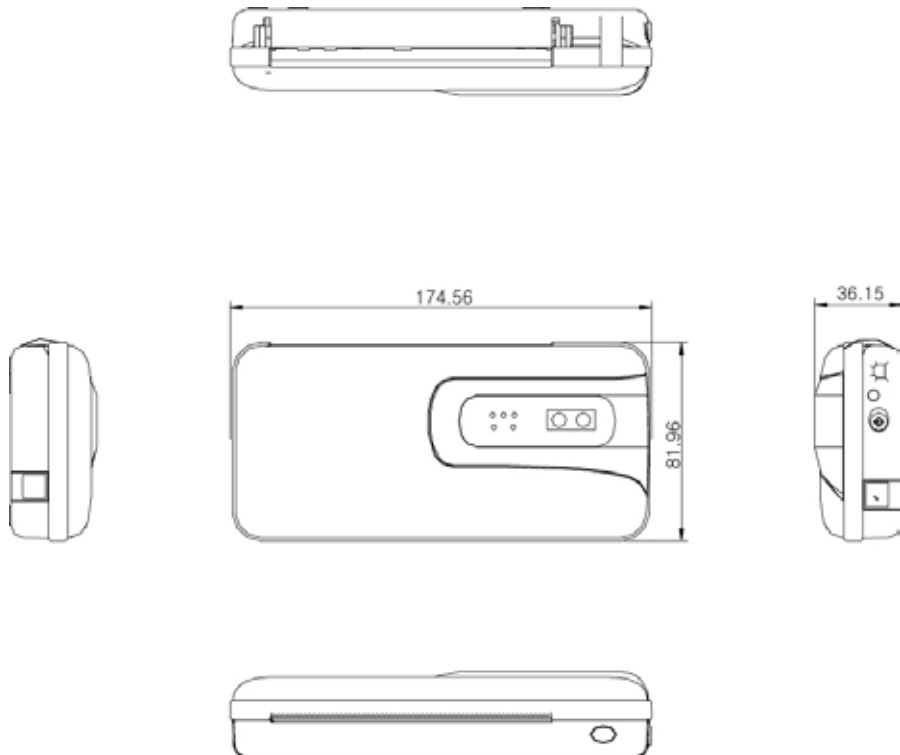

2.3. Replacing paper roll

Note : Be sure to use paper rolls that meet the specifications.

Do not use paper rolls that have the paper glued to the core because the printer can not detect the paper end correctly.

1. Make sure that the printer is not receiving data; otherwise, data may be lost.
2. Open the paper cover using finger on both side of printer, and remove the remaining paper.

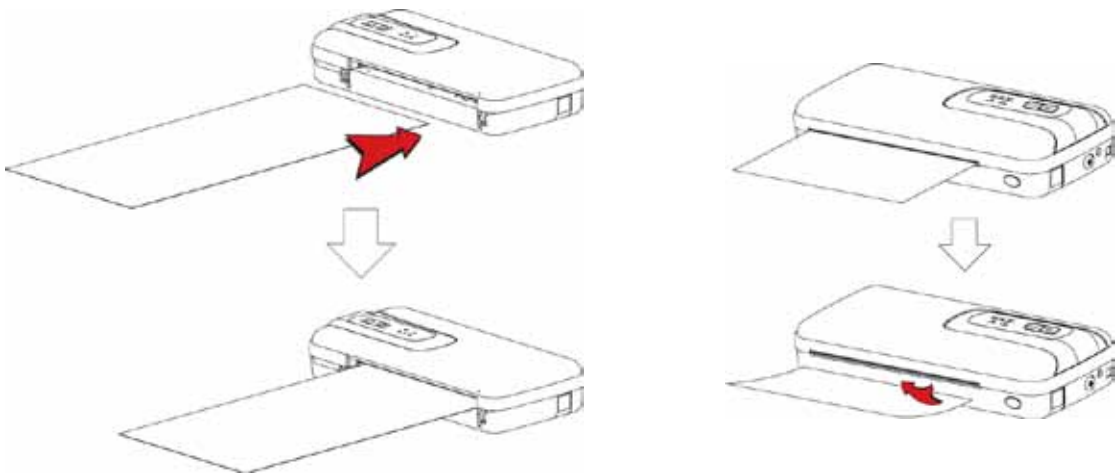

3. Insert the paper roll as shown.

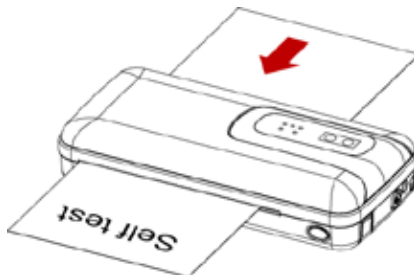

4. The label whole aspect product to wipe the head periodically.

The cleaning tool is buried the alcohol a little in the soft cotton ball as shown.

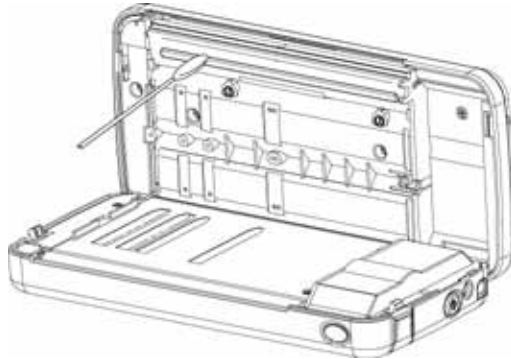

* Printer and the open apply lock buttons of arrow direction on side as shown.

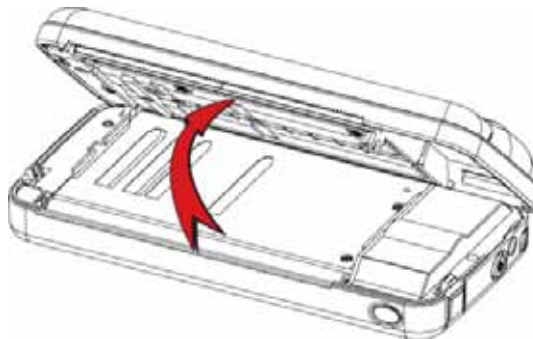
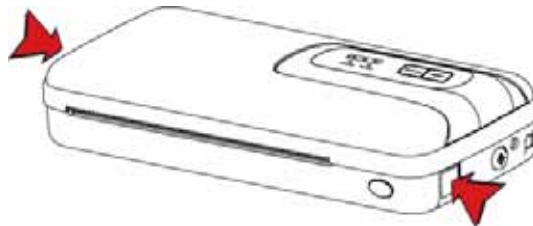

2.4. Power supply

2.4.1. Internal power supply

The following specification is requested for Power supply.

Battery Charger : DC 8.4V/0.8A

Avoid using power supply which its power capacity of power current is extremely high.

2.4.2. Installing the Battery

NOTE :

- Before installing or removing the battery pack, ensure the printer is OFF.
- If the printer is not used for long period of time, remove the battery pack from the printer.

To install battery pack, proceed as follows:

- Insert the Battery pack in the direction of the arrow.

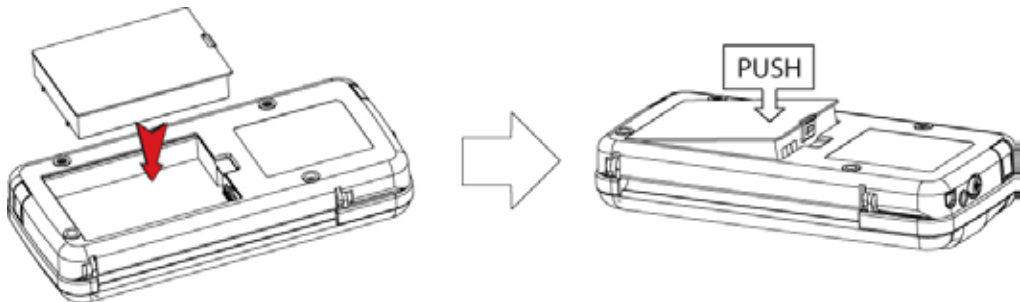

Removing the battery pack

- Turn the printer power off and push the battery pack lock and to lift up the direction of the arrow.

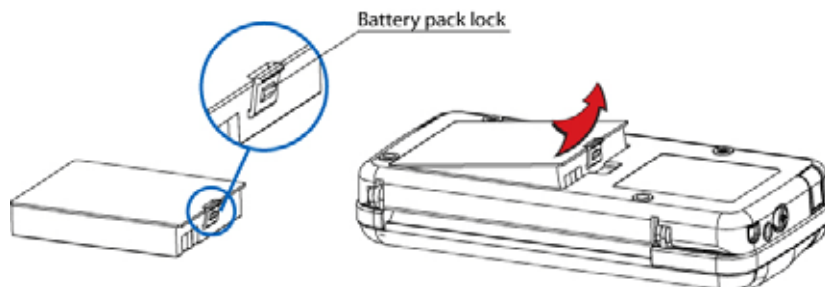

2.4.3. Recharging the battery pack

For recharging the battery pack, install the battery pack in the printer.
Insert the Battery Charger to the charge connector of the printer.



- NOTE :**
- While charging the printer, turn off the printer power.
 - Do not remove the battery during charging.
 - The battery is consumable parts and when purchasing, compared to the use hour is gradually decreases. (Warranty 6 month)
 - If the printer is not used for a long time, unplug the power cord from the printer and outlet.
 - The recharging time depends on the voltage level and ambient temperature of the battery. Normally, it takes about 4 to 5 hours to recharge a battery pack.
 - You must use only the supplied adapter.
 - Red Lamp : charging the battery.
Green Lamp: charging is finished.

2.5. Set operation mode

Change the mode and option using the MODE Code.

- | **MODE button** : use for changing OPTION status. (Error Lamp)
- | **FEED button** : use for changing MODE status. (Power Lamp)

[Example] The defaults of the printer are :

RS-232C / 9600 bps / 8 data bit / No parity / 1 stop bit / Density low
/ Mark use / Sensor low

If a user wants to modify the defaults with

Bluetooth / 57600 bps / 7 data bit / Odd parity / 2 stop bit / Density high
/ Mark no use / Sensor medium1

- U Press **MODE Button** during the **Error Lamp** flicking 5 times.
 - Ⓜ You will see the **Power Lamp** and the **Error Lamp** flickers once.
 - Ⓜ Press the **MODE Button** twice and the **Error Lamp** flickers 3 times.
And then, interface mode has set to **Bluetooth** mode.
- U When you press **FEED button** once again, **Power Lamp** flickers twice and the **Error Lamp** flickers once.
 - Ⓜ Press **MODE Button** 3 times, **Error Lamp** flickers 4 times.
And then, baudrate has set to **57,600 bps**.
- U When you press **FEED Button** once again, **Power Lamp** flickers 3 times and the **Error Lamp** flickers twice.
 - Ⓜ Press **MODE Button** once, **Error Lamp** flickers once.
And then Data Bit has set to **7 data bit**.
- U When you press **FEED Button** once again, **Power Lamp** flickers 4 times and the **Error Lamp** flickers once.
 - Ⓜ Press **MODE Button** once, **Error Lamp** flickers twice.
And then the Parity bit has set to **Odd parity bit**.
- U When you press **FEED Button** once again, **Power Lamp** flickers 5 times and **Error Lamp** flickers once.
 - Ⓜ Press **MODE Button** once, **Error Lamp** flickers twice.
And then the density has set to **2 stop bit**.

- ⌋ When you press **FEED Button** once again, **Power Lamp** flickers 6 times and **Error Lamp** flickers once.
- Ⓜ Press **MODE Button** twice, **Error Lamp** flickers 3 times.
And then the density has set to **Density high**.
- ⌋ When you press **FEED Button** once again, **Power Lamp** flickers 7 times and **Error Lamp** flickers twice.
- Ⓜ Press **MODE Button** once, **Error Lamp** flickers once
And then the mark has set to **Mark no use**.
- ⌋ When you press **FEED Button** once again, **Power Lamp** flickers 8 times and **Error Lamp** flickers once.
- Ⓜ Press **MODE Button** once, **Error Lamp** flickers twice
And then the sensor has set to **Sensor medium1**.

If all the mode have set, press the **MODE Button** and the **FEED Button** at the same time after then release the buttons at the same time.

The printer will print out the mode status which has modified.

(Bluetooth / 57600 bps / 7 data bit / Odd parity / 2 stop bit / Density high / Mark no use / Sensor medium1)

If the status is not correct, please try it again according to the procedure.

* IrDA Version

| MODE | POWER Lamp (Green) | ERROR Lamp (Red) | Option |
|--------------------|-----------------------|---------------------|----------------|
| Communication Port | 1 | 1 | UART |
| | | 2 | Protocol UART |
| | | 3 | Raw IrDA |
| | | 4 | Protocol IrDA |
| | | 5 | Standard IrDA |
| Baud Rate | 2 | 1 | 9600 bps |
| | | 2 | 19200 bps |
| | | 3 | 38400 bps |
| | | 4 | 57600 bps |
| | | 5 | 115200 bps |
| Data Bit | 3 | 1 | 7 Data bit |
| | | 2 | 8 Data bit |
| Parity Bit | 4 | 1 | No Parity |
| | | 2 | Odd Parity |
| | | 3 | Even Parity |
| Stop Bit | 5 | 1 | 1 Stop bit |
| | | 2 | 2 Stop bit |
| Density | 6 | 1 | Density Low |
| | | 2 | Density Medium |
| | | 3 | Density High |
| Mark | 7 | 1 | No use |
| | | 2 | Use |
| Sensor | 8 | 1 | Low |
| | | 2 | Medium1 |
| | | 3 | Medium2 |
| | | 4 | High |

< Table 2 >

* Bluetooth Version

| MODE | POWER Lamp (Green) | ERROR Lamp (Red) | Option |
|-----------------------|-----------------------|---------------------|--------------------|
| Communication Port | 1 | 1 | UART |
| | | 2 | Protocol UART |
| | | 3 | Bluetooth |
| | | 4 | Protocol Bluetooth |
| Baud Rate | 2 | 1 | 9600 bps |
| | | 2 | 19200 bps |
| | | 3 | 38400 bps |
| | | 4 | 57600 bps |
| | | 5 | 115200 bps |
| Data Bit | 3 | 1 | 7 Data bit |
| | | 2 | 8 Data bit |
| Parity Bit | 4 | 1 | No Parity |
| | | 2 | Odd Parity |
| | | 3 | Even Parity |
| Stop Bit | 5 | 1 | 1 Stop bit |
| | | 2 | 2 Stop bit |
| Density | 6 | 1 | Density Low |
| | | 2 | Density Medium |
| | | 3 | Density High |
| Mark | 7 | 1 | No use |
| | | 2 | Use |
| Sensor | 8 | 1 | Low |
| | | 2 | Medium1 |
| | | 3 | Medium2 |
| | | 4 | High |

< Table 3 >

3. Interface

3.1. UART(RS-232C or TTL)

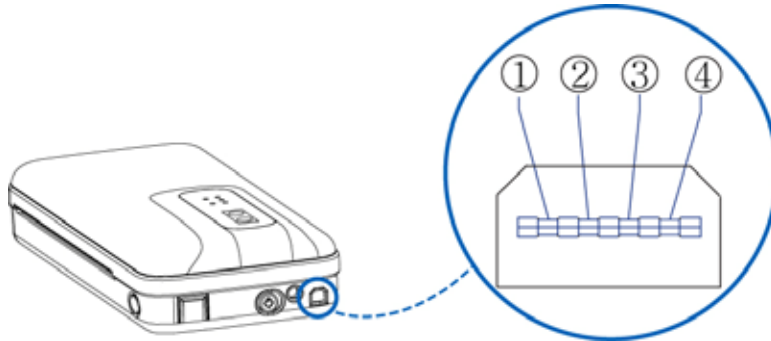

The WSP-HS400 printer has a UART(RS-232C or TTL) interface and is connected by means of a 4 pin mini USB socket. In the following table, the signals present on the Mini USB socket are listed:

| Pin No. | Name | Direction | Function |
|---------|------|-----------|---------------|
| 1 | TxD | Output | Transmit Data |
| 2 | RxD | Input | Receive Data |
| 3 | CTX | - | - |
| 4 | GND | - | Ground |

* Applicable connector : SUNG KYUNG (CM-720)

NOTE : ● When data receiving, when it removes the communication cable, it loses a data.

3.2. Infrared data communication

The WSP-HS400 has a serial interface for bi-directional data exchange. The infrared port is the right side of the front part.

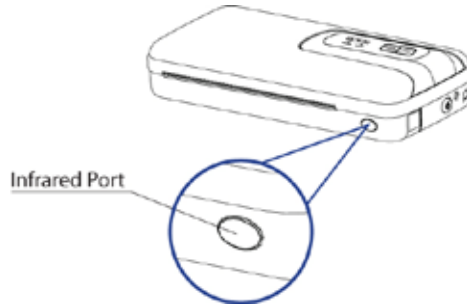

1. To use the WSP-HS400's infrared port by a Computer or a Personal Digital Assistant (PDA) with IR port is required.
2. Position a PDA conforming to the specifications in point not more than 50 centimeter away from the printer's infrared port. Make sure the two ports are in front of each other with an angle of not more than 15° on the four sides.

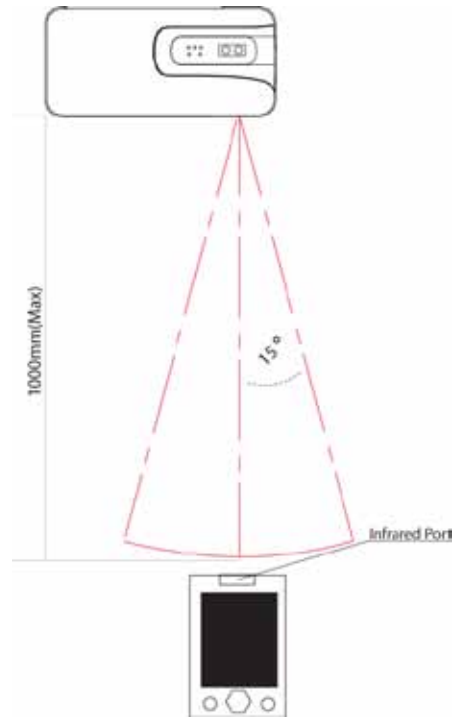

NOTE : ● When infrared ray communication doing, directness it does not see the IrDA window roll up.
Eye damage there is a danger.

3.3. Bluetooth

| Category | Specification |
|------------------------|---------------------------------------|
| Bluetooth Spec. | Bluetooth Ver2.1 + EDR / Class2 (10m) |
| Frequency Range | 2.4GHz ISM BAND |
| Data Transmission Rate | 57600bps Fixed. |
| Data bit | 8 Data bit Fixed. |
| Parity bit | No parity Fixed. |
| Stop bit | 1 Stop bit Fixed. |

4. Using the printer

4.1. Control panel

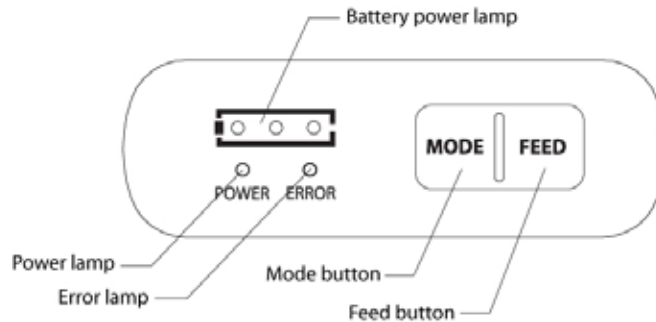

⌋ Button

- FEED :

When the printer is on, paper can be feed manually by pressing and holding the FEED button for more than one second.

- MODE :

MODE Button is for use to change communication mode.

Do not operate the mode button without instructions.

⌋ Panel lamp

- **Power :** Printer is ON and ready to receive data.

- **Error :** Indicates a fault condition or a printer error.
(i.e : no paper, paper cover opened. etc.)

- **Battery Power :** These lamps(**Green**) indicated the battery power remaining.

The battery gain in quantity and these lamps are on the decrease.

If so, you must recharge the battery by using the battery charger.

4.2. Self test

The Self-Test checks whether the printer has any problems. If the printer does not function properly, contact your dealer. For Self-Test, turn on the power while holding down the FEED Button. The Self-Test checks the following :

- 1) Make sure paper roll has been installed properly.
- 2) The Self-Test prints the current printer status, which provides the control ROM version and the communication method setting.
- 3) After printing the current printer status, Self-Test will print a pattern using the built-in character set.
- 4) The Self-Test automatically ends.

The printer is ready to receive data as soon as it complete the Self-Test.

5. Consumable parts

5.1. Recommended paper

| | |
|-----------------|--|
| Type | : Thermal Label Paper |
| Paper width | : 116mm (Standard) Optional width – 56, 58, 80, 82.5 ,87, 89, 91, 98, 100, 102, 112, 114mm |
| Paper thickness | : 0.15 mm or less |



Cautions

1. Do not paste the paper to the core, and the roll paper which has near end mark printing on its near end is recommended.
2. Chemicals or oil may change the color of paper, or printed characters may fade.
3. Change of paper color starts from approx. 70 .
Pay attention to heat, humidity and sun light.
4. Color of paper may be changed by being scratched by nail or hard metal, etc.

5.2. Printing position

